

DUR-A-GLAZE MVP Primer

DESCRIPTION

Dur-A-Flex DUR-A-GLAZE MVP PRIMER is a clear, 100% solids epoxy moisture mitigation system installed under any epoxy-based Dur-A-Flex flooring system. It is formulated to bond to concrete with relative humidity (RH) as high as 95%. It is designed to reduce moisture vapor emission levels up to 20 lbs/1000 sq. ft./24 hours to 3 lbs/1000 sq. ft./24 hours or less.

BENEFITS

- Reduces moisture levels to 3 lbs./1,000 sq. ft./24hours or less
- VOC 0 g/L
- Typical one coat application
- Excellent adhesion
- Resistant to high Ph

PACKAGING

DUR-A-GLAZE MVP PRIMER is available in 1-gallon cans, 5-gallon pails and 50-gallon drums.

SURFACE PREPARATION

This product requires preparation in order to perform as expected. Surface must be profiled, clean, dry, oil free and sound. Please refer to the [Surface Preparation Guide](#) for more information.

Perform anhydrous calcium chloride tests per ASTM F1869 for to determine moisture vapor emission rates and/or in situ probe method testing per ASTM F2170 to determine relative humidity levels.

NOTE: If replacing VCT, note that salt concentration is typically higher where tiles meet. Dur-A-Flex highly recommends core analysis along joint lines prior to installation of any resinous floor system.

APPLICATION METHOD/ SPREAD RATES

Pour 2 parts resin into 1 part hardener and mix for 2 minutes using a jiffler-type mixer at 300 – 450 rpm.

DUR-A-GLAZE MVP PRIMER is applied with a 3/16 inch V-notched squeegee and back-rolled

with a 3/8 inch nap roller cover. An application rate of 100 sq.ft./gallon to yield a dry film thickness of 16 mils is recommended.

NOTE: Out-gassing may occur in very porous concrete. To address this, apply a second coat of DUR-A-GLAZE MVP PRIMER mixed with an equal amount of Cab-O-Sil. Apply using a flat squeegee at 250 – 350 square feet per mixed gallon.

LIMITATIONS

- For interior applications only
- Apply only to properly prepared, sound and stable concrete at least 5 days old.
- DUR-A-GLAZE MVP PRIMER is to be applied at substrate temperatures between 60° F and 90° F.
- Do not apply when RH of concrete is greater than 95% (at 40% depth of slab) or moisture vapor transmission levels are greater than 20 lbs/1000 sq. ft./24 hours
- Recoat window of within 24 hours must be adhered to.
- Do not use as a stand-alone system
- Available clear only

WARRANTY

A 10 year warranty is available for approved applications with the submission of a warranty application form. The form can be found at www.dur-a-flex.com in the Contractor Center.

NOTE: DUR-A-GLAZE MVP PRIMER is a moisture mitigation system designed to reduce moisture vapor emission only.

JOINT GUIDELINES

Construction, Expansion and Isolation joints are considered moving joints which allow horizontal and vertical movement between the slab and adjoining structures, such as walls and columns, helping to minimize cracking where the two meet.

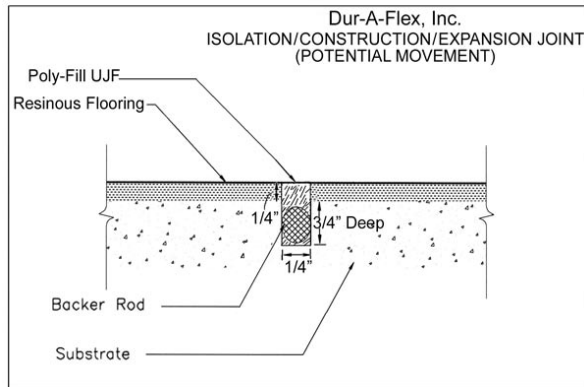

Prior to filling moving joints Dur-A-Flex, Inc. recommends “honoring” these joints by making a saw cut through the finished floor system at a depth of 3/4” deep and 1/4” wide with a diamond blade saw attached to a vacuum. A bond breaker such as backer rod (closed cell) must be added to the bottom of the joint. Use Poly-Fill UJF to fill joint.

Be sure to mark the location of the joints prior to the installation of the finished floor.

Non-Moving Joints

Control and or Contraction joints are considered non-moving joints which accommodate shrinkage and relieve internal stresses during the curing process of the concrete. Fill joints as follows: Mix 1 part Dur-A-Glaze MVP hardener with 2 parts Dur-A-Glaze MVP resin and thicken with 3 parts Cab-0-Sil.

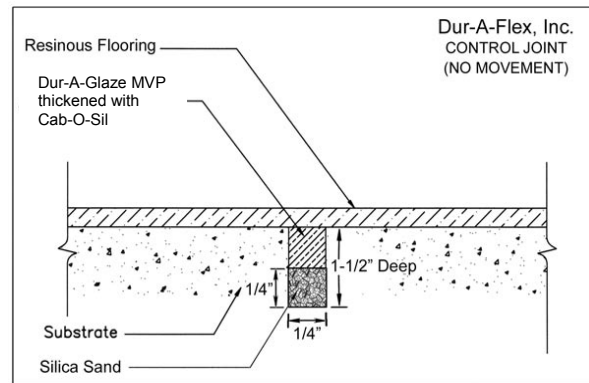

Before using any Dur-A-Flex, Inc. product, be sure the Material Safety Data Sheet is read and understood.

DUR-A-GLAZE MVP PRIMER

TECHNICAL INFORMATION

Resin type	Epoxy
Color	Clear
% Solids	100%
Mix Ratio (by volume)	2 resin to 1 hardener
Viscosity at 70°F (mixed hardener & resin)	1,400 cps
Pot Life at 70°F	45 minutes
Recoat range at 70°F	12 – 24 hours
Foot traffic	24 hours
Cured Film Thickness	16 mils at 100 sq. ft. per gallon
Shelf life	1 year when stored in original packaging at 73° F
VOC	0 g/L

Physical Property	Test Method	Result
Hardness, Shore D	ASTM D-2240	75-80
Compressive Strength	ASTM D-695	11,200 psi
Flame Spread /NFPA-101	ASTM E-84	Class A
Tensile Strength	ASTM D-638	2,100 psi
Flexural Strength	ASTM D-790	5,100 psi
Bond Strength to Concrete	ACI-40	Substrate Failure
Water Absorption	MIL D-24613	Nil